

2

1

B

B

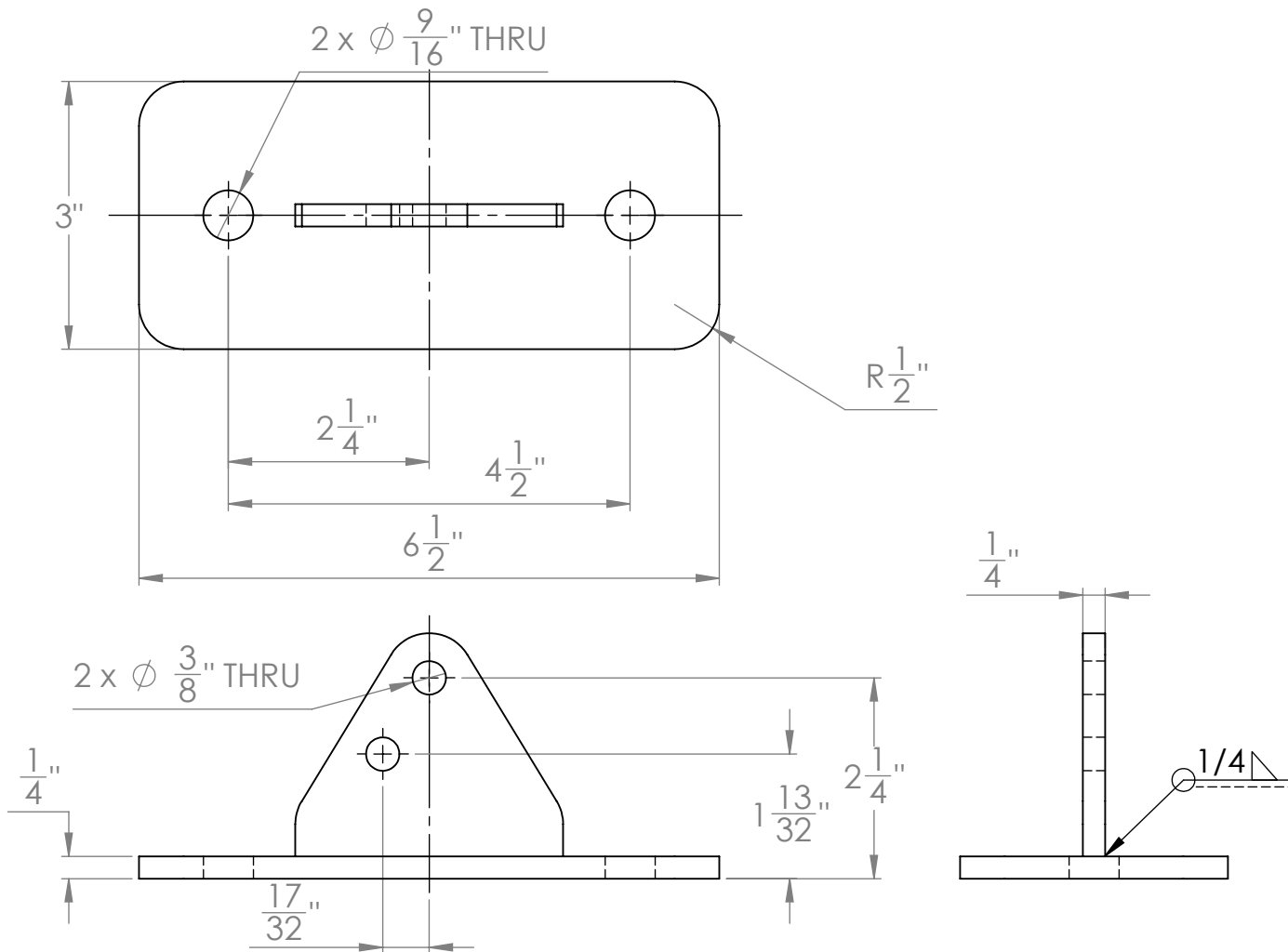

A

A

**PROPRIETARY AND CONFIDENTIAL**  
 THE INFORMATION CONTAINED IN THIS DRAWING IS THE SOLE PROPERTY OF SOLIEX, INC. ANY REPRODUCTION IN PART OR AS A WHOLE WITHOUT THE WRITTEN PERMISSION OF SOLIEX, INC IS PROHIBITED.

		UNLESS OTHERWISE SPECIFIED:		NAME	DATE
		DIMENSIONS ARE IN INCHES	DRAWN	DG	6/23/2022
		TOLERANCES:	CHECKED		
		FRACTIONAL $\pm 1/32$	ENG APPR.		
		ANGULAR: MACH $\pm 1$ BEND $\pm 1$	MFG APPR.		
		TWO PLACE DECIMAL $\pm .01$	Q.A.		
		THREE PLACE DECIMAL $\pm .005$	COMMENTS:		
		INTERPRET GEOMETRIC TOLERANCING PER: ASME Y14.5 - 2009			
		MATERIAL:			
		Plain Carbon Steel			
		FINISH			
NEXT ASSY	USED ON				
APPLICATION		DO NOT SCALE DRAWING			

SOLIEX, INC.

TITLE:  
Guy Wire Mount

SIZE	DWG. NO.	REV
<b>A</b>	126.1811	
SCALE: 1:5	WEIGHT:	SHEET 1 OF 1

2

1